

KATO MEJA RIAS

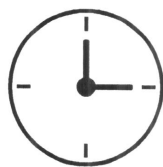

60 Menit

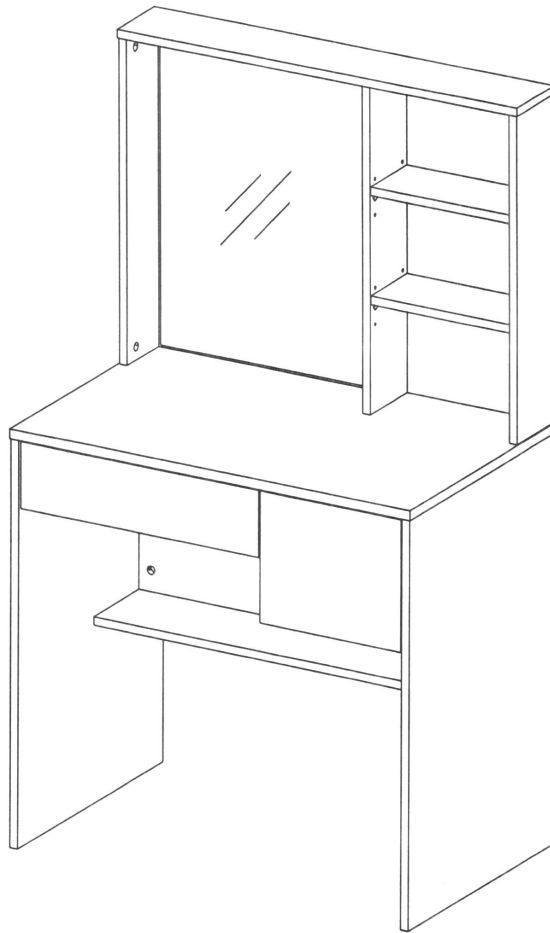

2 Orang

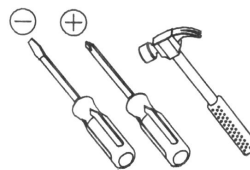

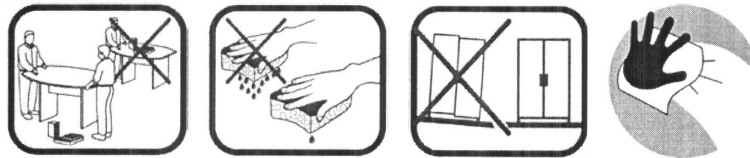
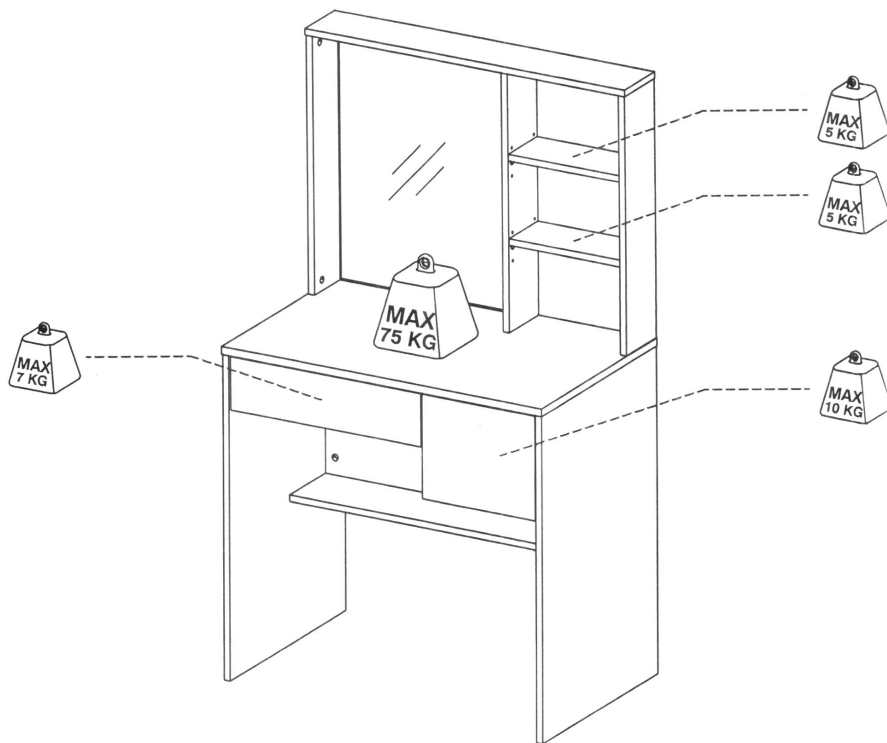

1. Beban pada ilustrasi di bagian **INFORMASI PRODUK** adalah beban dalam keadaan diam dengan distribusi merata pada semua permukaan.
2. Pindahkan produk ini dengan cara mengangkat, jangan didorong karena dapat merusak bagian kaki.
3. Bila terkena cairan, langsung bersihkan dengan menggunakan kain yang lembut.
4. Jangan meletakkan benda-benda bersuhu tinggi tanpa menggunakan alas.
5. Permukaan produk tidak boleh terkena cairan kimia. contoh : thinner, cat kuku.
6. Membersihkan produk cukup dengan kain kering, namun bila diperlukan dapat menggunakan kain lembab bukan basah. Pelengkap pengaman wajib digunakan untuk mencegah furnitur terjatuh. Pelengkap pengaman sudah termasuk di dalam paket furnitur ini dan cara instalasi tercantum.
7. Jangan memanjat atau bergelantungan di laci, pintu atau rak.
8. Letakkan benda berat di laci paling bawah.
9. Engsel dapat disetel agar pintu sejajar dan mudah untuk dibuka tutup, setting engsel secara perlahan dan jangan dipaksa.
10. Laminasi permukaan menggunakan material dasar Kertas.
11. Jangan meletakkan benda panas langsung diatas permukaan. Selalu gunakan tatakan penahan panas. Terdapat resiko permukaan bergelembung akibat kontak fisik dengan benda panas akibat penguapan lapisan adhesif antara papan kayu dengan lapisan laminasi.
12. Jangan meletakkan benda basah langsung diatas permukaan. Selalu gunakan tatakan agar permukaan tidak terkena cairan. Terdapat resiko permukaan berubah warna dan lapisan menjadi lapuk akibat kontak fisik dengan benda basah.
13. Kaca merupakan *tempered glass* sehingga lebih kuat dari kaca tanpa *treatment*, namun hindari penggunaan yang terlalu kasar seperti membanting saat menutup pintu dan hindari kaca terkena benda keras atau tajam dengan kencang.

PARTS LIST

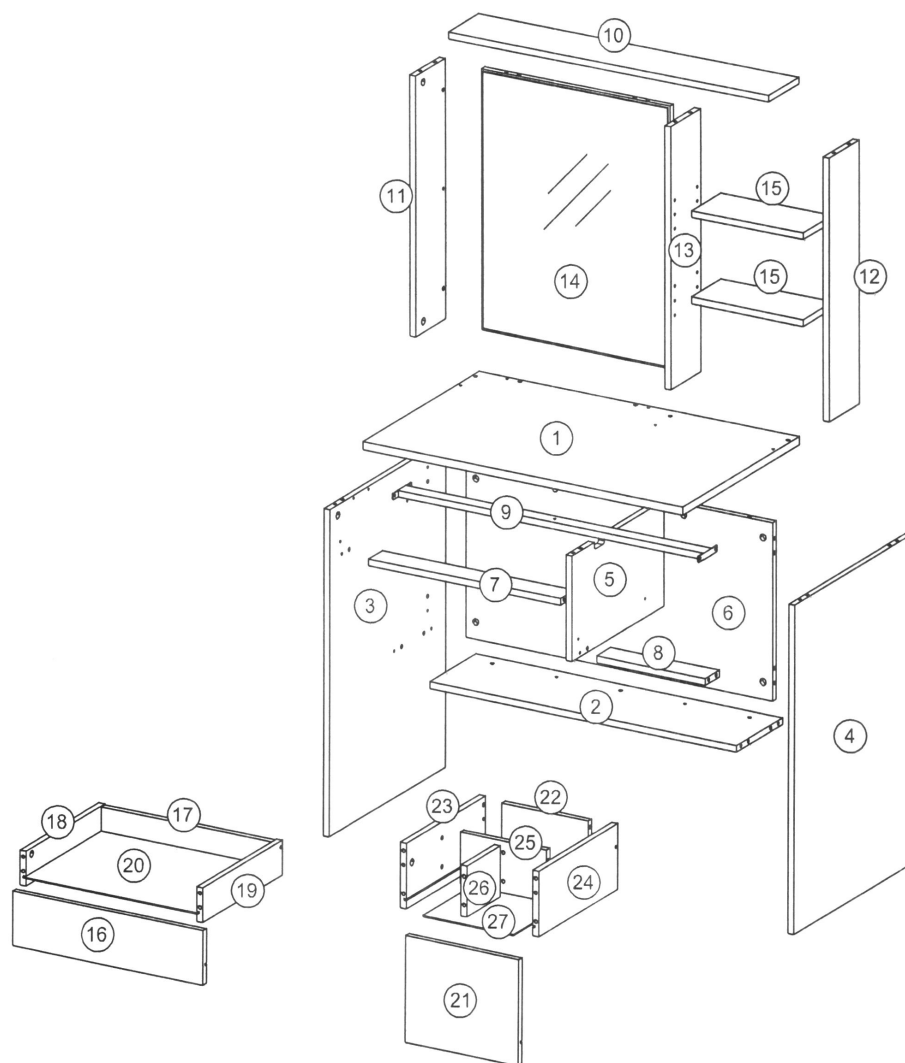

No.	Size	Qty
1	796 x 500 x 18 mm	1
2	763 x 198 x 15 mm	1
3	732 x 498 x 15 mm	1
4	732 x 498 x 15 mm	1
5	235 x 396 x 15 mm	1
6	763 x 396 x 15 mm	1
7	478 x 60 x 15 mm	1
8	270 x 60 x 15 mm	1
9	762 x 80 x 15 mm	1
10	796 x 130 x 15 mm	1

No.	Size	Qty
11	585 x 128 x 15 mm	1
12	585 x 128 x 15 mm	1
13	585 x 128 x 15 mm	1
14	575 x 460 x 3 mm	1
15	276 x 126 x 15 mm	2
16	472 x 120 x 15 mm	1
17	423 x 76 x 15 mm	1
18	340 x 78 x 15 mm	1
19	340 x 78 x 15 mm	1
20	434 x 336 x 2.5 mm	1



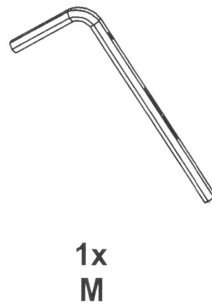
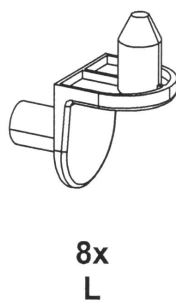
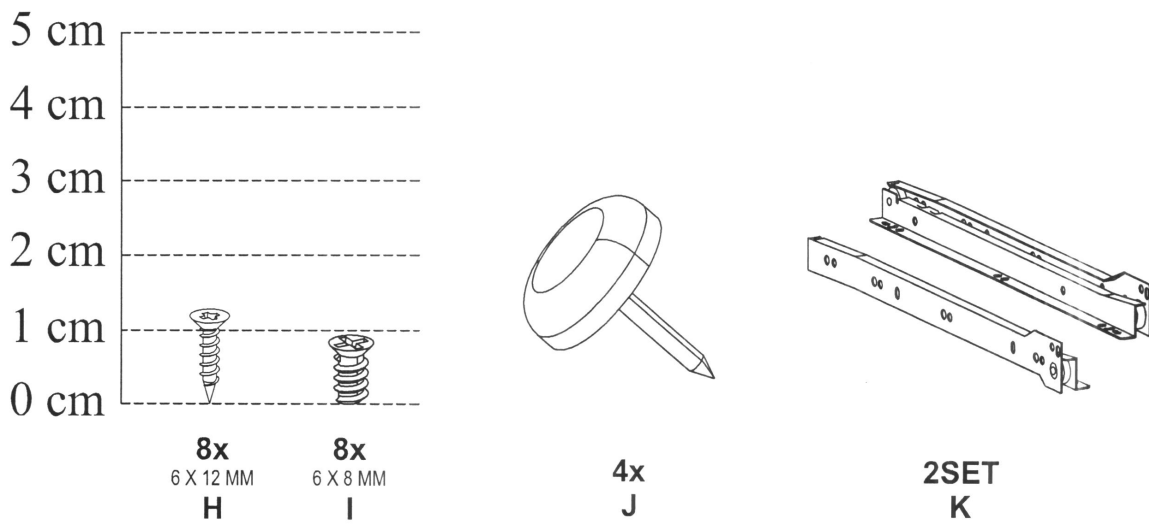
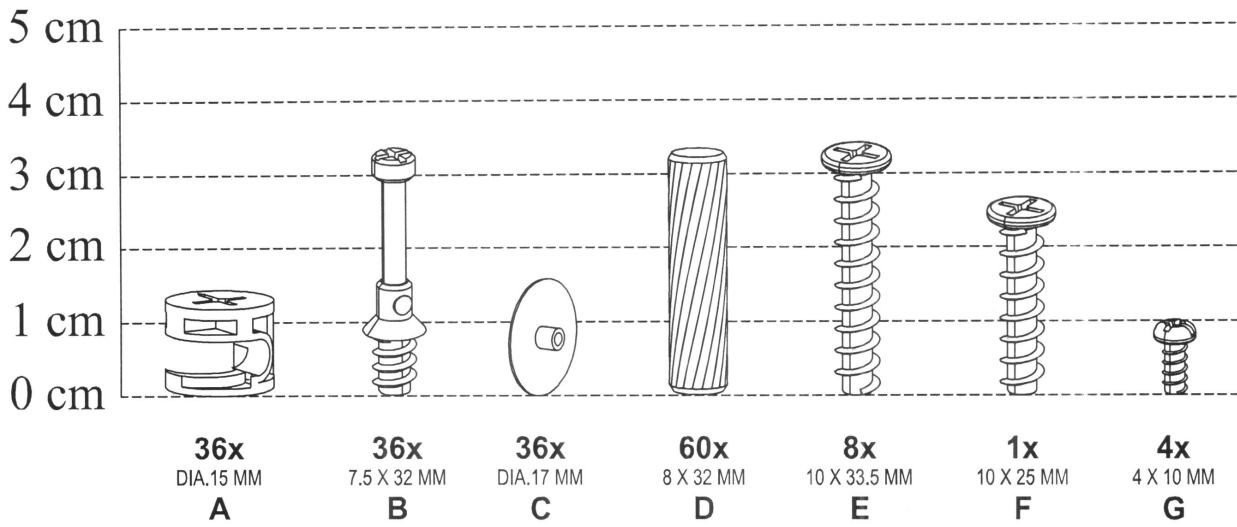

No.	Size	Qty
21	282 x 235 x 15 mm	1
22	215 x 144 x 15 mm	1
23	340 x 146 x 15 mm	1
24	340 x 146 x 15 mm	1
25	215 x 115 x 15 mm	1
26	145 x 114 x 15 mm	1
27	226 x 336 x 2.5 mm	1

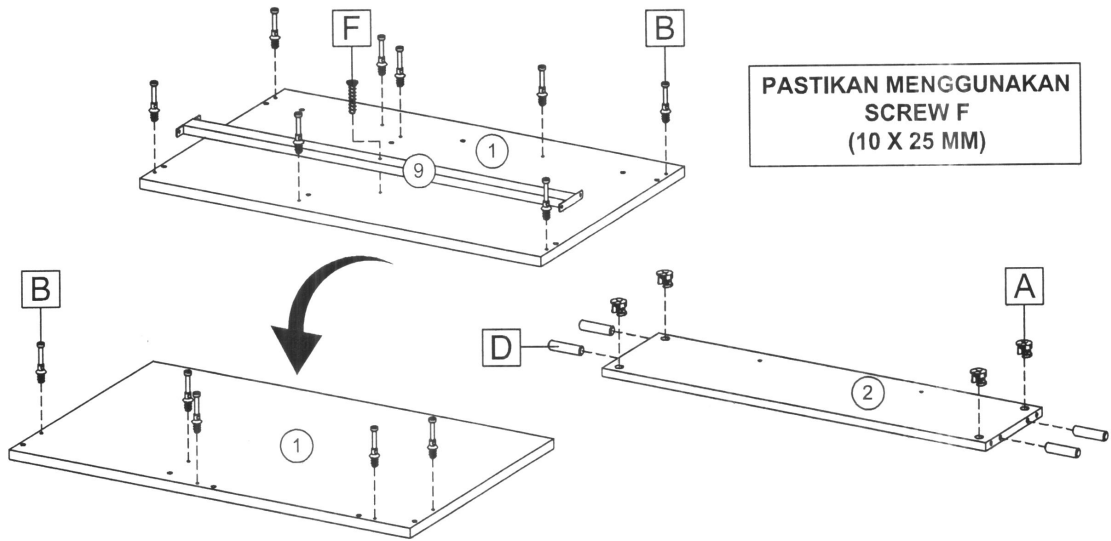
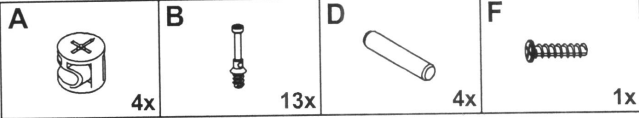
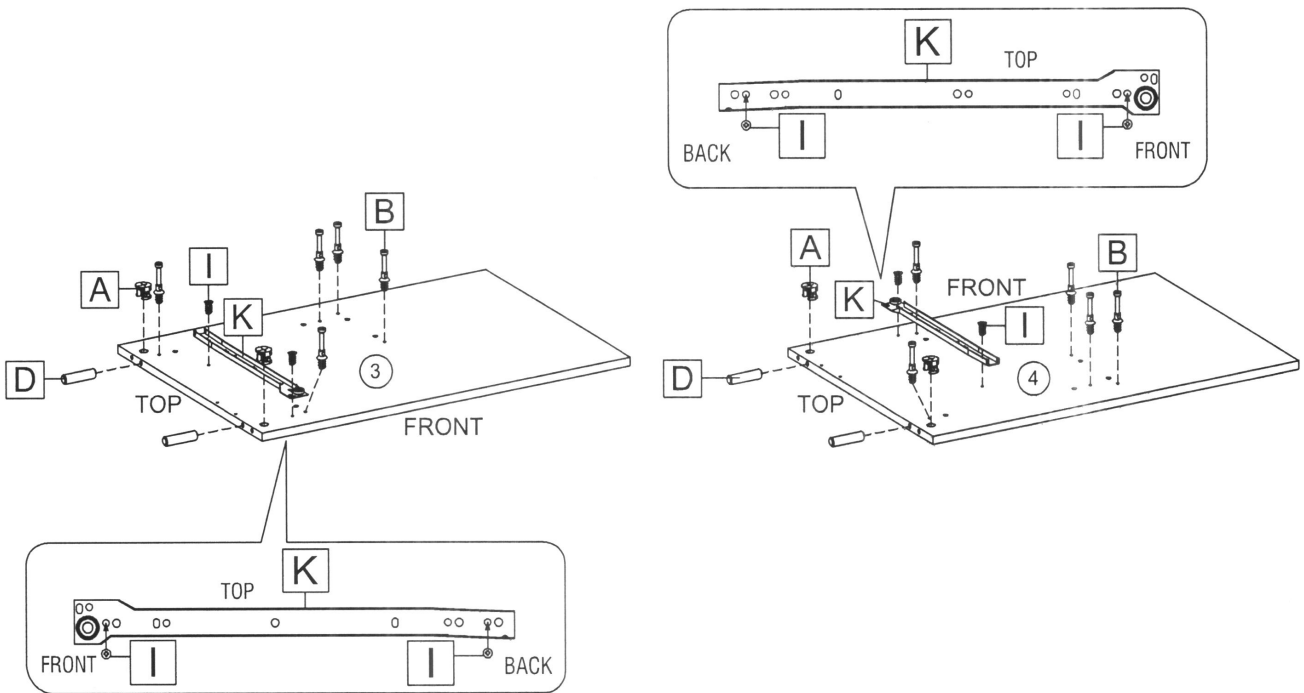
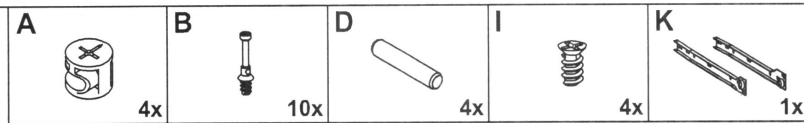
HARDWARE LIST





1**2**

3

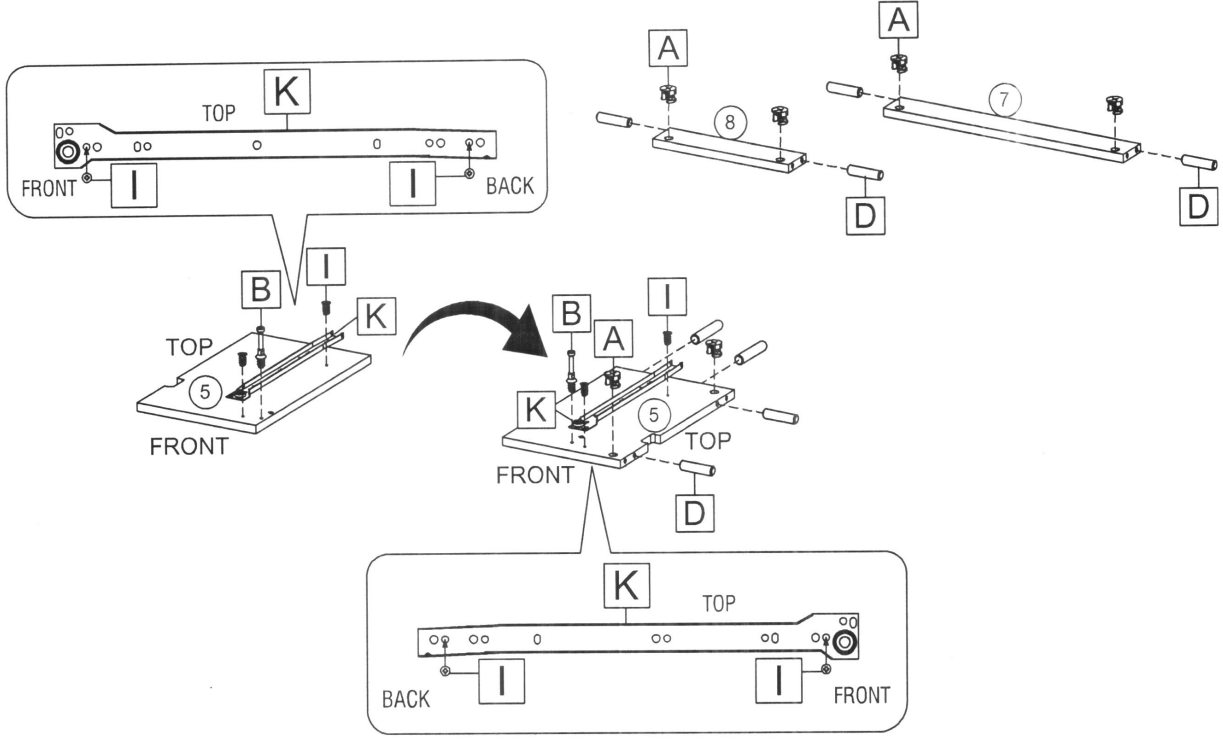
- A**

 6x
- B**

 2x
- D**

 8x
- I**

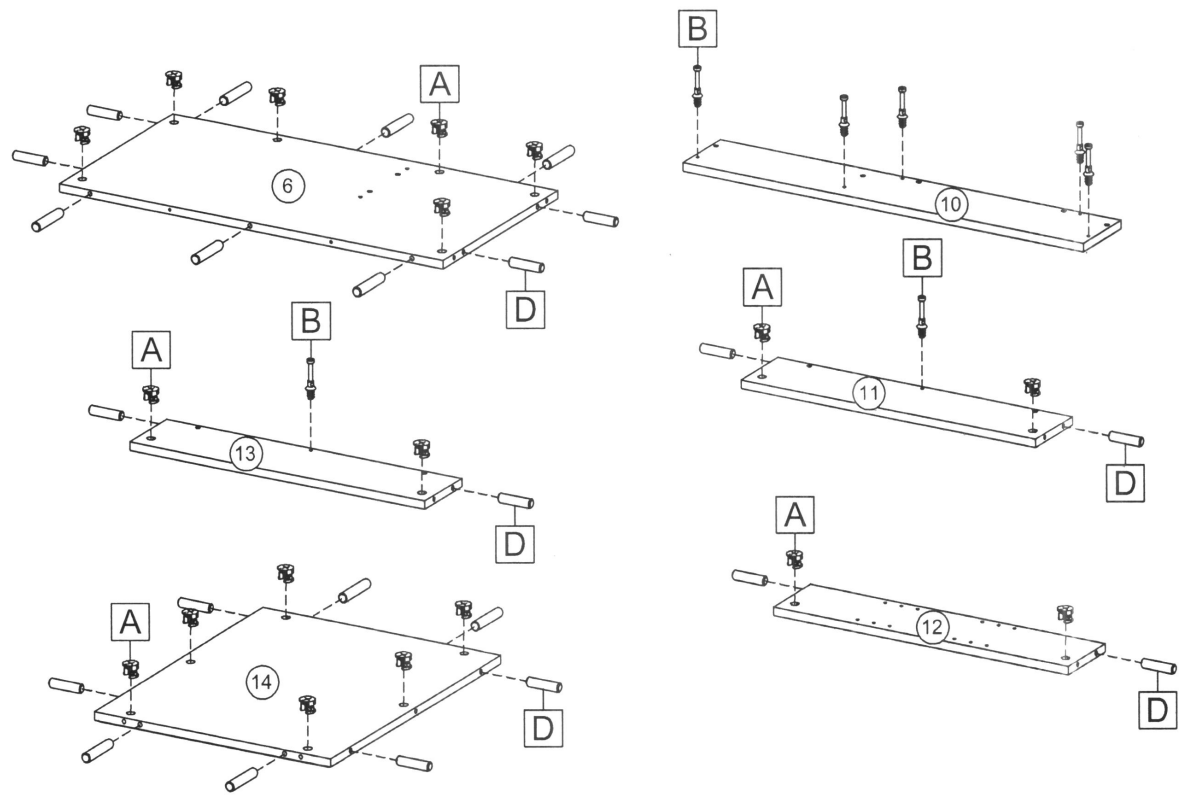
 4x
- K**

 1x



4

- A**

 18x
- B**

 7x
- D**

 24x



5

E



4x

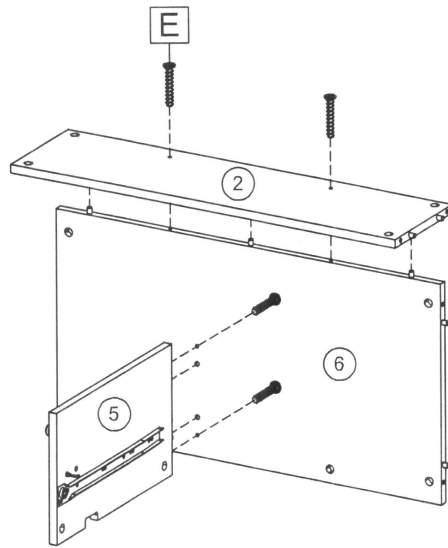

PASTIKAN MENGGUNAKAN
SCREW E
(10 X 33.5 MM)

6

C



12x

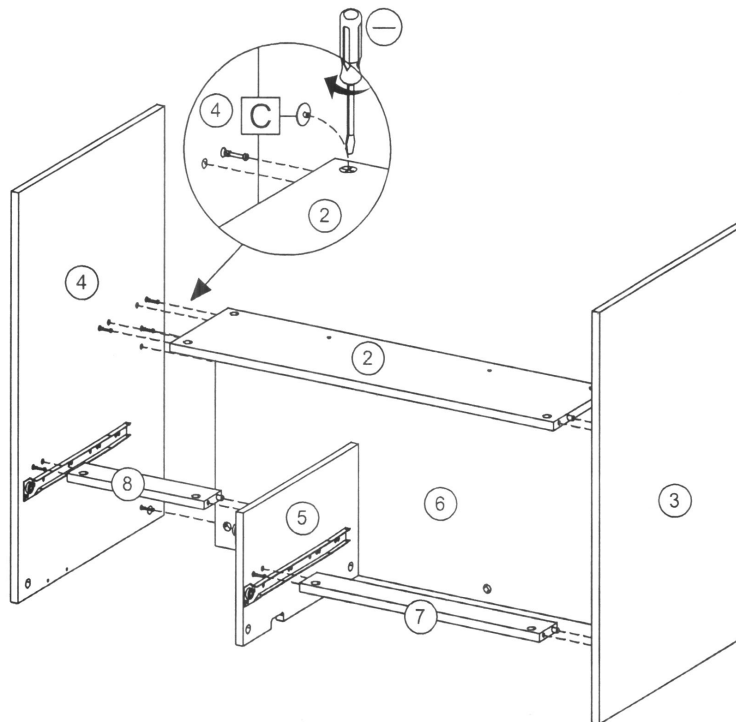

7

J



4x

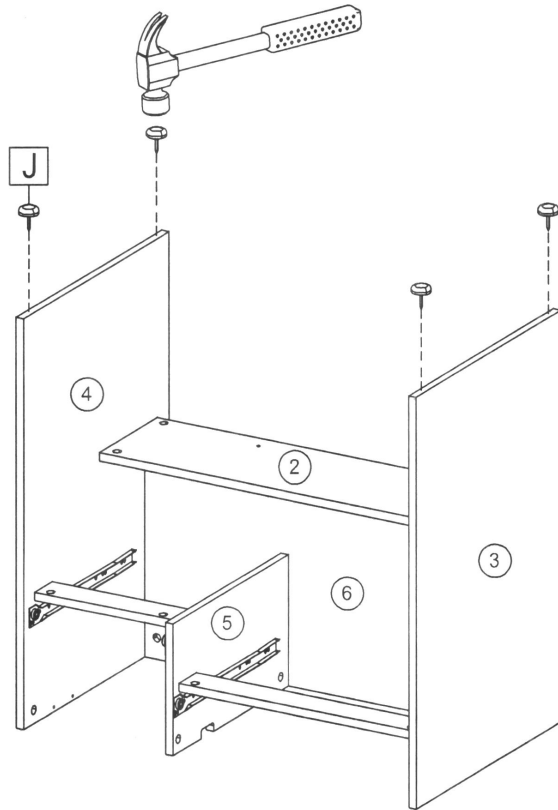

8

C



8x

G



4x

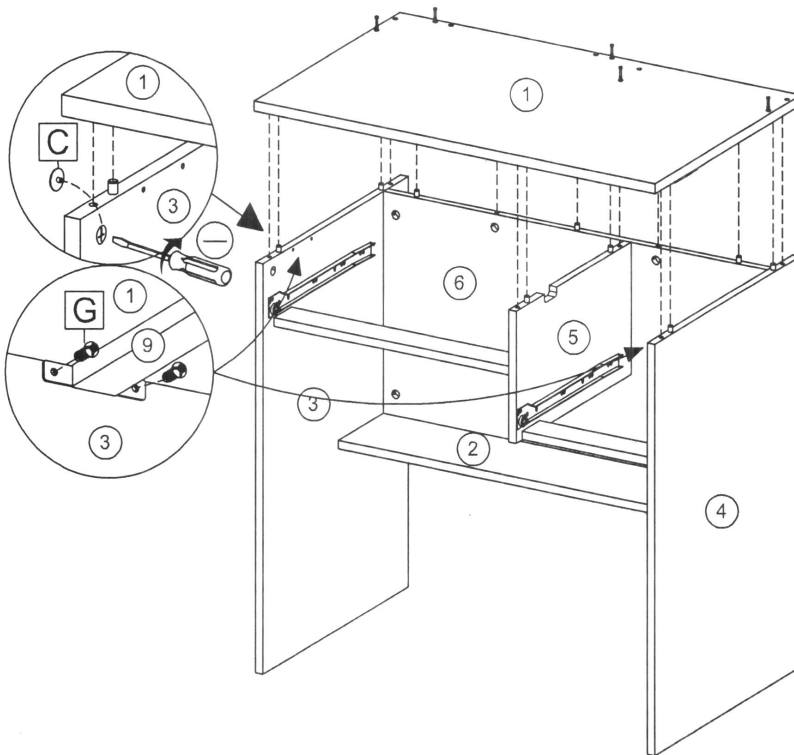

9

C



2x

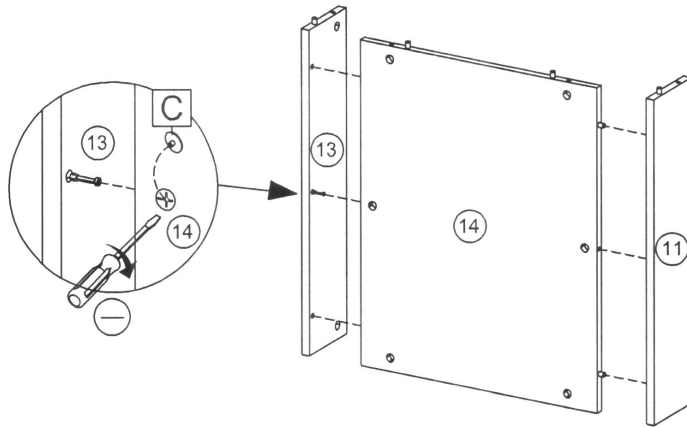

10

C



5x

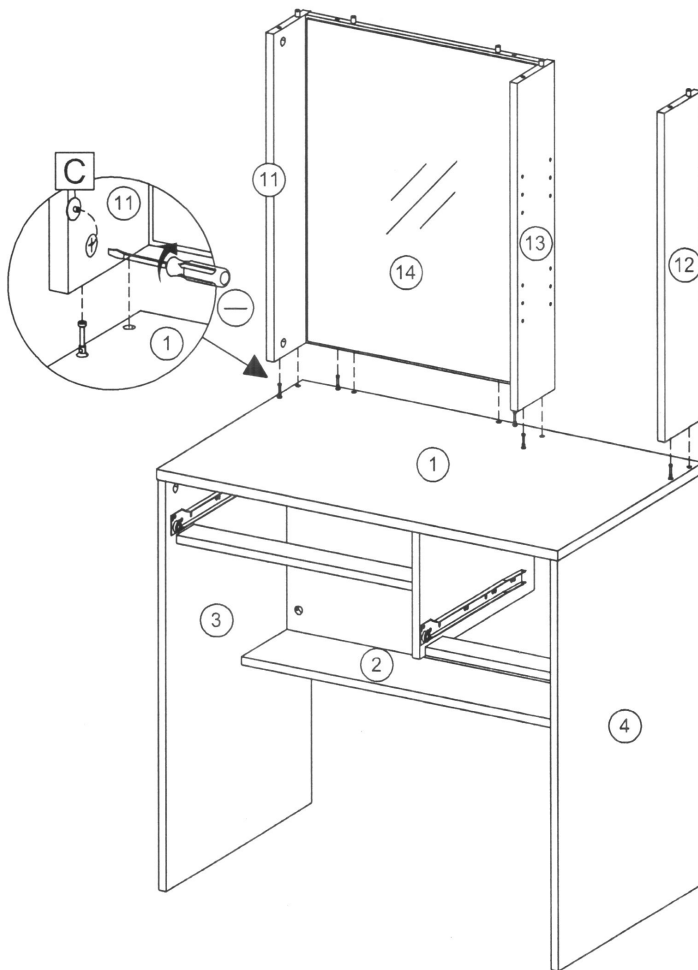

11

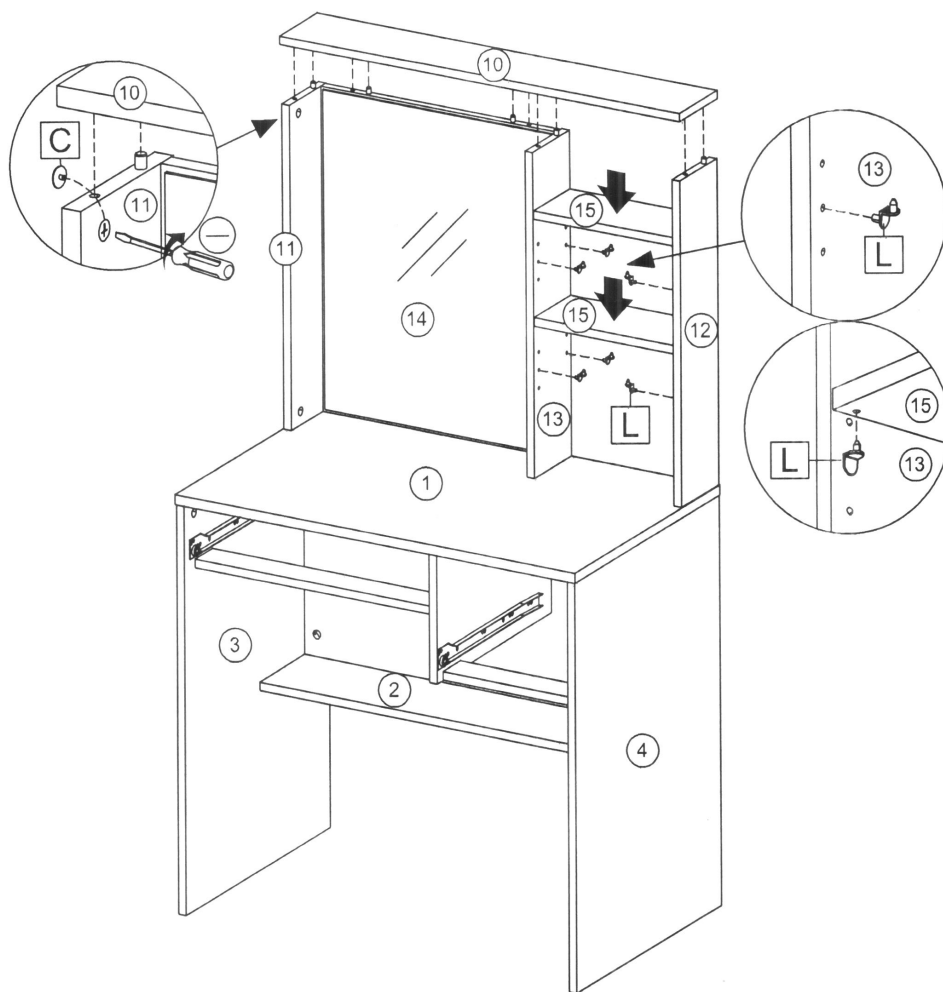
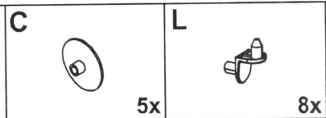

12

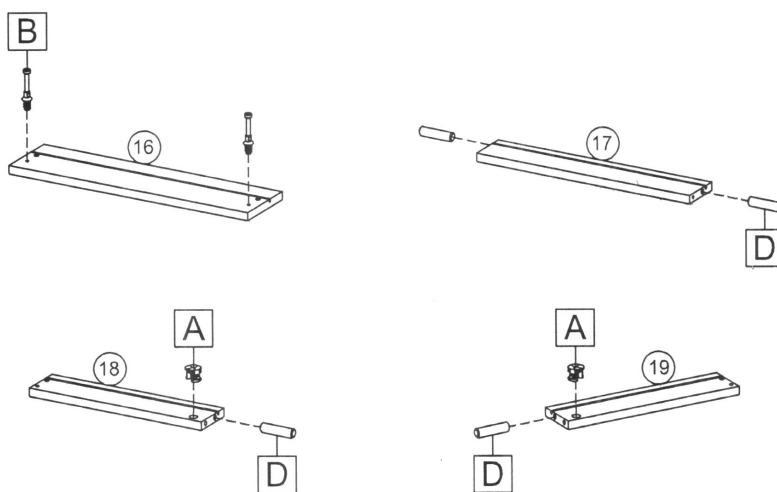
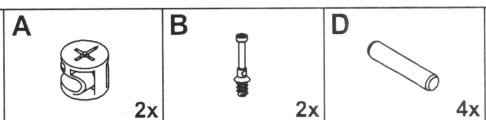

13

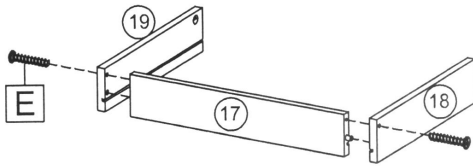
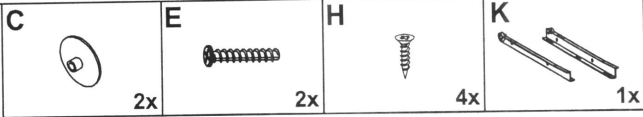

PASTIKAN MENGGUNAKAN
SCREW E
(10 X 33.5 MM)

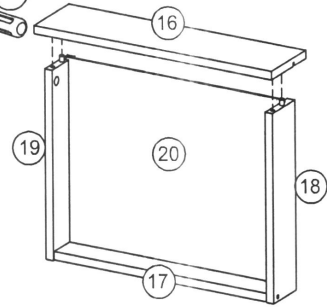
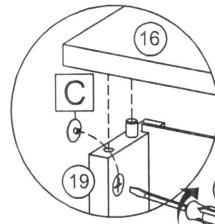
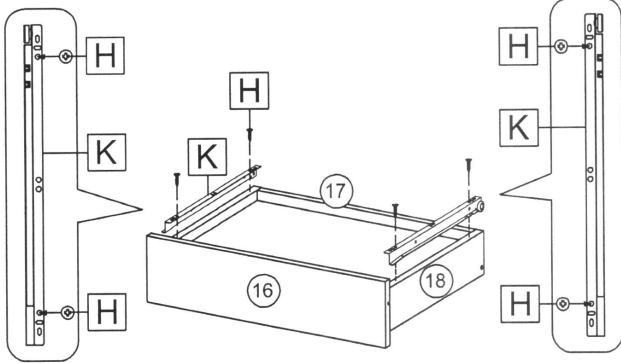
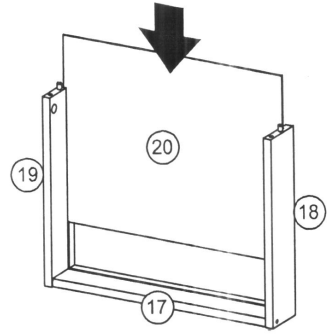

14

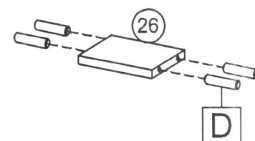
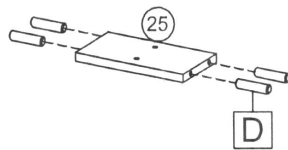
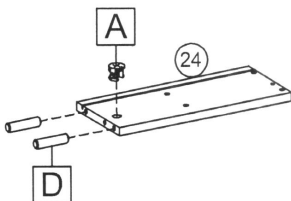
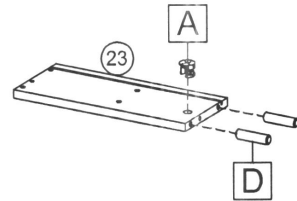
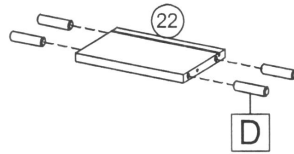
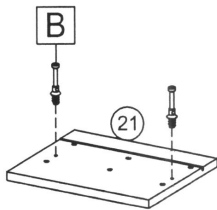
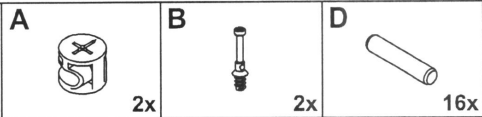

15

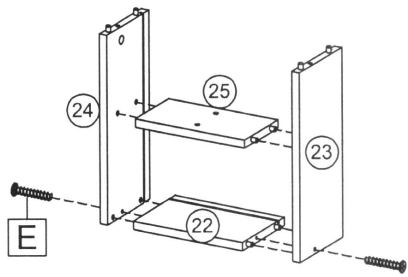
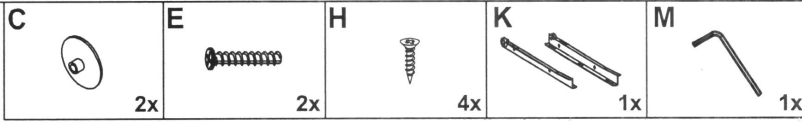

**PASTIKAN MENGGUNAKAN
SCREW E
(10 X 33.5 MM)**

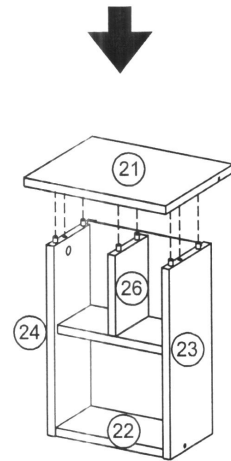
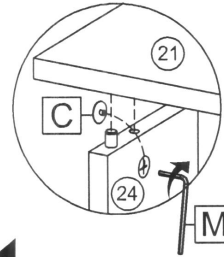
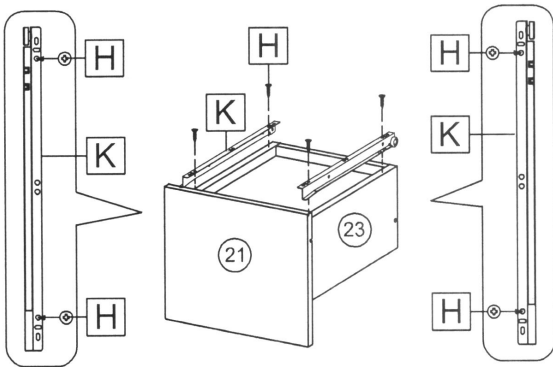
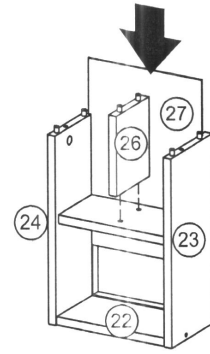

16

